

Intermittent Bagmaker M250



We used our broad engineering expertise to design our M-series VFFS machines. The M250's rugged construction and enclosed jaw drive makes this VFFS bag-maker an excellent choice for dusty or wet environments.

max.
speed

100
bpm

bag
size

max.
250 mm × 400 mm (9.84" × 15.75")
min.
50 mm × 60 mm (1.97" × 2.36")

Bag Types

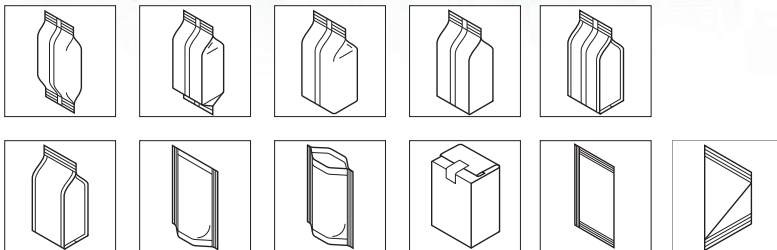

Bag Options

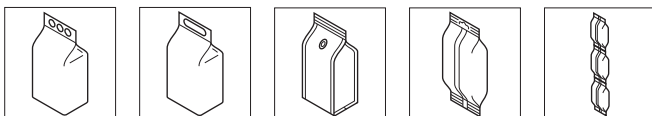

Recloseable Solutions



Intermittent Bagmaker M250 In Detail

A rugged powerhouse, the M250 is a high-performance vertical form fill and seal machine that offers the flexibility of open modular design – at an affordable price. The fast-action jaw boasts 100 bags per minute. With bag dimensions of up to 250 mm wide (optional 400 mm bag width) by 400 mm long in a single stroke, plus a host of bag styles, the M250 is flexible, functional and economical. Like all our VFFS machines, it has a linear actuator film web edge guide that aligns film with the forming tube. Your result? An extremely accurate and user friendly machine that fulfills all of your packaging needs!

features

- › Robust stainless steel frame
- › Enclosed, direct drive jaw actuation
- › Siemens or Allen Bradley control
- › Off-the-shelf components
- › Minimal maintenance requirements
- › Short film path
- › Small machine footprint
- › No tool change-over
- › Self-centering pull belts
- › Automatic film tracking
- › VFD powered film unwind
- › Quick film splice table
- › Photo eye and encoder
- › Tri-fold guard door
- › Jaw obstruction detection
- › Runs most film structures
- › Storage for 100 product recipes

options

- › Quad seal bag assembly
- › Flat bottom bag assembly
- › Upgrade for 300mm bag width
- › Impulse sealing for poly film structures
- › Washdown IP66 construction
- › Vacuum pull belts
- › Hole punch (Euroslot or Round)
- › Product stagers
- › End-seal cooling air
- › Bag deflators
- › Load shelf
- › Product settler
- › Gas flush
- › Static eliminator
- › Tear notch
- › Degassing valve applicator
- › Remote diagnostics
- › Zipper applicator
- › In-feed and take-away conveyors
- › Integration with variety of fillers, printers, metal detectors, label applicators, and checkweighers

Machine drawings

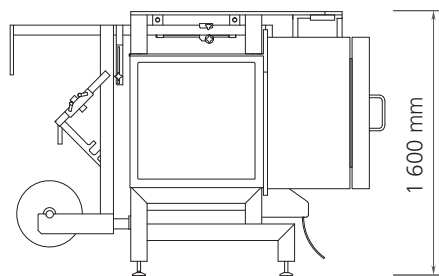
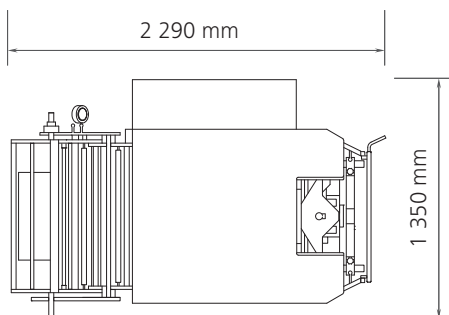

Max. speed
100 bpm

Weight
750 kg (1,655 lbs)

Bag width
50–250 mm
(1.97”–9.84”)

Air pressure
6 bar
(15–18 CFM at 90 PSI)

Bag length
60–400 mm
(2.36”–15.75”)

Power supply
6 kVA
(480 V, three phase,
60 Hz., 20 AMPS)

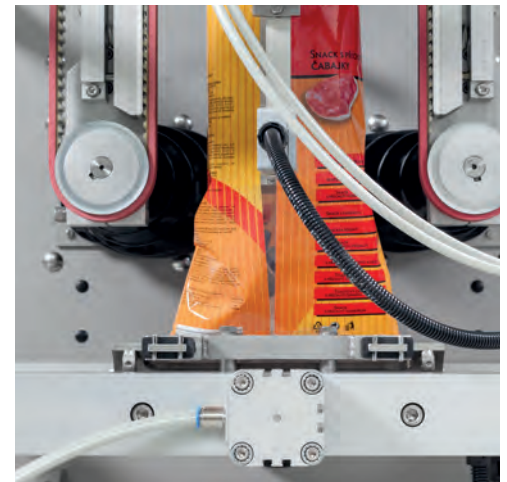

Europe, Asia, Africa, Australia

Viking Mašek, a.s. | Průmyslová 1747 | 258 01 Vlašim | Czech Republic

Phone +420 317 850 500 | **Email** info@masek.cz | **Website** www.masek.cz, www.vikingmasek.cz

North and South America

Viking Masek Global Packaging Technologies, Inc. | 40 Woodland Court | Oostburg, WI 53070 | USA

Phone +1 920 564 5051 | **Email** sales@vikingmasek.com | **Website** www.vikingmasek.com