

Intermittent Bagmaker M400



The M400, one of our most versatile baggers, is able to make quad seal, flat bottom, doy style, brick fold down / tape down, and pillow bags – all on one machine. The M400 is a robust stainless steel machine capable of running large bags up to 400 mm wide and 500 mm long.

max. speed 100 bpm

bag size max. 400 mm x 500 mm (15.75" x 19.69")
min. 60 mm x 60 mm (2.36" x 2.36")

Bag Types

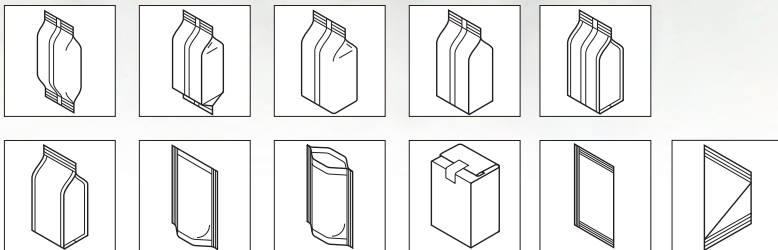

Bag Options

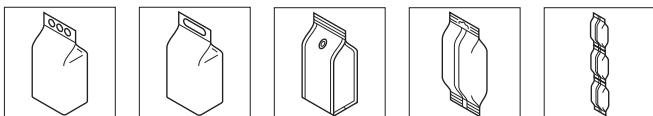

Recloseable Solutions



Intermittent Bagmaker M400 In Detail

Offering a host of bag styles up to 400 mm wide and 500 mm long in a single stroke, the M400 is a high-performance vertical form fill and seal machine that offers the flexibility of open modular design – at an affordable price. The fast-action jaw boasts 100 bags per minute. Flexible and functional, the M400 offers all the benefits of its smaller M250 cousin. This bagger packs incredible speed, efficiency and economy into an ultimate packaging powerhouse!

features

- > Robust stainless steel frame
- > Enclosed, direct drive jaw actuation
- > Siemens or Allen Bradley control
- > Off-the-shelf components
- > Minimal maintenance requirements
- > Short film path
- > Small machine footprint
- > No tool change-over
- > Self-centering pull belts
- > Automatic film tracking
- > VFD powered film unwind
- > Quick film splice table
- > Photo eye and encoder
- > Tri-fold guard door
- > Jaw obstruction detection
- > Runs most film structures
- > Storage for 100 product recipes

options

- > Quad seal bag assembly
- > Flat bottom bag assembly
- > Impulse sealing for poly film structures
- > Washdown IP66 construction
- > Vacuum pull belts
- > Hole punch (Euroslot or Round)
- > Product stagers
- > End-seal cooling air
- > Bag deflators
- > Load shelf
- > Product settler
- > Gas flush
- > Static eliminator
- > Tear notch
- > Degassing valve applicator
- > Remote diagnostics
- > Zipper applicator
- > In-feed and take-away conveyors
- > Integration with variety of fillers, printers, metal detectors, label applicators, and checkweighers

Max. speed
100 bpm

Weight
1 100 kg (2,425 lbs)

Bag width
60–400 mm
(2.36"–15.75")

Air pressure
6 bar
(15–18 CFM at 90 PSI)

Bag length
60–500 mm
(2.36"–19.69")

Power supply
6 kVA
(480 V, three phase,
60 Hz., 20 AMPS)

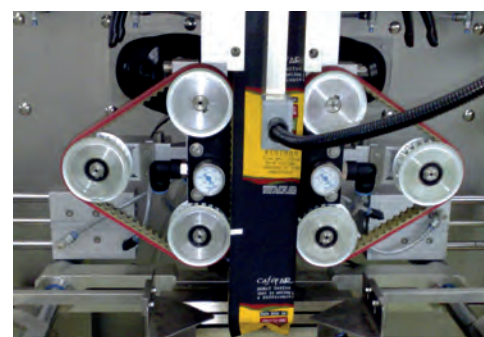
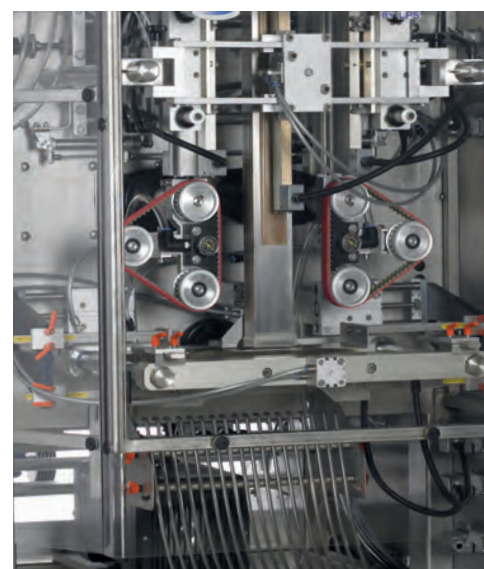

Machine drawings

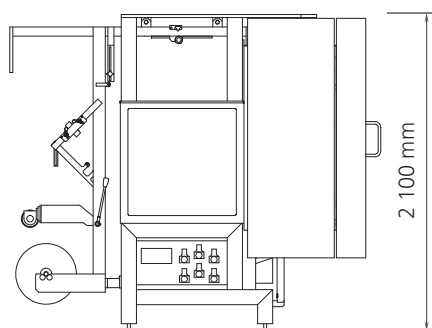
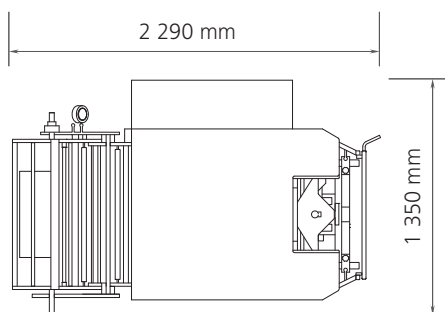

Europe, Asia, Africa, Australia

Viking Mašek, a.s. | Průmyslová 1747 | 258 01 Vlašim | Czech Republic

Phone +420 317 850 500 | **Email** info@masek.cz | **Website** www.masek.cz, www.vikingmasek.cz

North and South America

Viking Masek Global Packaging Technologies, Inc. | 40 Woodland Court | Oostburg, WI 53070 | USA

Phone +1 920 564 5051 | **Email** sales@vikingmasek.com | **Website** www.vikingmasek.com