

Intermittent Bagmaker S400

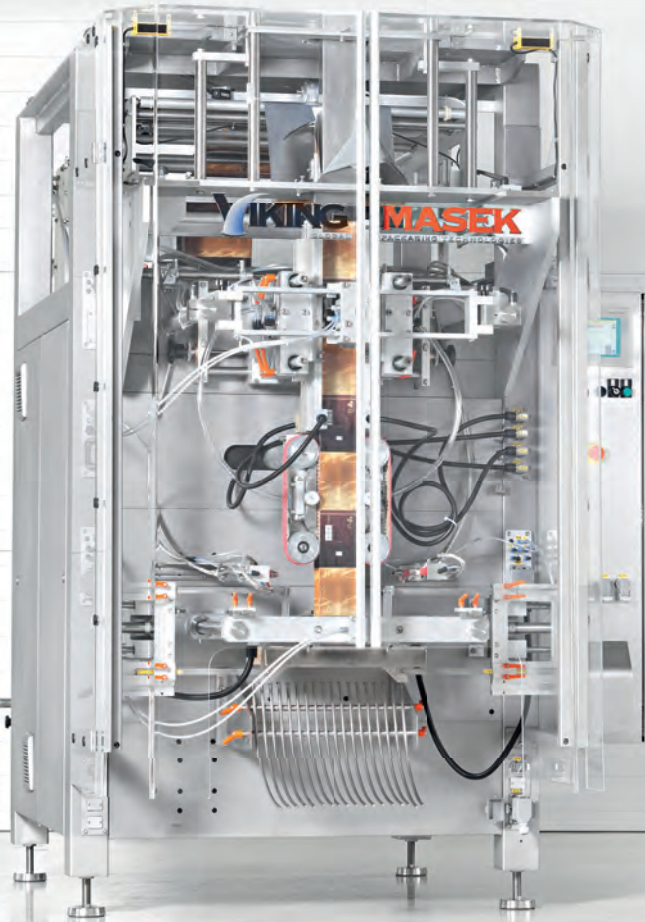

This robust, servo-driven vertical bagger makes such good-looking quad seal bags, your competitors will think they're pre-made! The S400 is perfect for packaging large bags of snacks, candy, coffee, pet food, powders and more.

max.
speed

100
bpm

bag
size

max.
400 mm x 600 mm (15.75" x 23.62")
min.
100 mm x 100 mm (3.94" x 3.94")

Bag Types

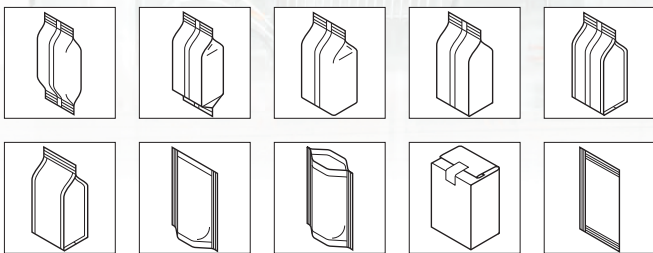

Bag Options

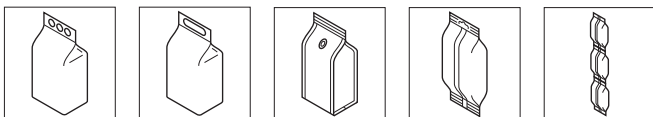

Recloseable Solutions



Intermittent Bagmaker S400 In Detail

It is often said that life is a series of trade-offs, but who said anything about your bagger? With the S400 you get all the benefits you need – speed, flexibility and affordability – in one robust servo-driven machine. And this form, fill and seal powerhouse has a rugged design while accommodating multiple bag designs and dimensions. Did we mention speed? At 100 bags per minute, this speed demon will zip through all your production runs. Why settle for a bagger with trade-offs when the S400 packs all the benefits you want in one powerful machine!

features

- › Robust, stainless steel frame
- › Siemens or Allen Bradley control system
- › Servo-drive jaw actuation
- › Open frame design
- › Off-the-shelf components
- › Minimal maintenance requirements
- › Short film path
- › Small machine footprint
- › No tool changeover
- › Self-centering pull belts
- › Automatic film tracking
- › VFD powered film unwind
- › Quick film splice table
- › Photo eye and encoder
- › Automatic machine stop
- › Jaw obstruction detection
- › Runs most film structures
- › Storage for 100 product recipes

Machine drawings

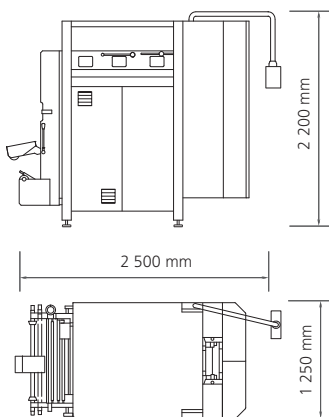

options

- › Continuous motion mode
- › Ultrasonic sealing jaws
- › Quad seal bag assembly
- › Doy bag assembly
- › Servo pull belts actuation
- › Flat bottom bag assembly
- › Impulse sealing for poly film structures
- › Washdown IP66 construction
- › Vacuum pull belts
- › Fold-down/tape-down unit
- › Hole punch (Euroslot and Round)
- › Load shelf
- › Product settler
- › Gas flush
- › Static elimination
- › Tear notch
- › Product staggers
- › End-seal cooling air
- › Bag deflators
- › Degassing valve applicator
- › Remote diagnostics
- › Zipper applicator
- › Bag-in-bag configuration
- › Integration with variety of fillers, printers, metal detectors, label applicators, and checkweighers
- › In-feed and take-away conveyors

Max. speed
100 bpm

Weight
1 300 kg (2,865 lbs)

Bag width
100–400 mm
(3.94"–15.75")

Air pressure
6 bar
(12–20 CFM at 90 PSI)

Bag length
100–600 mm
(3.94"–23.62")

Power supply
8.4 kVA
(480 V, three phase,
50/60 Hz., 20 AMPS)

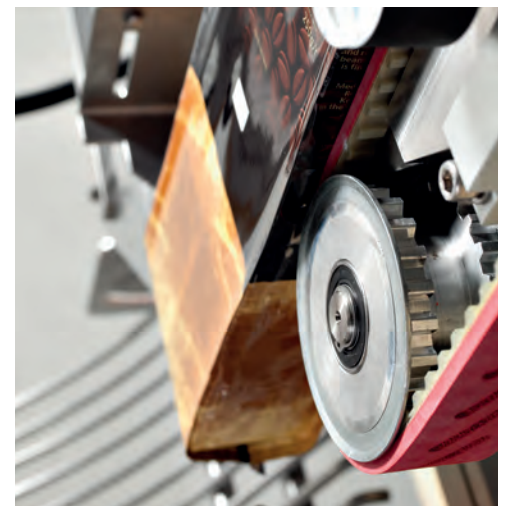
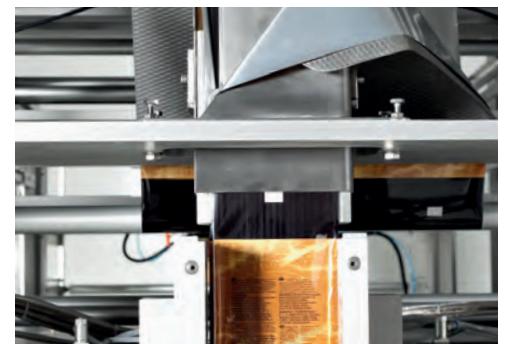
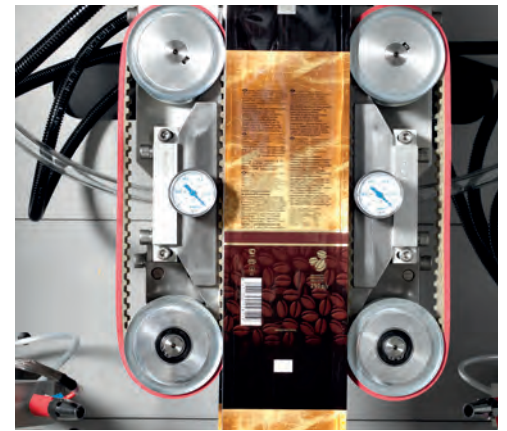

Europe, Asia, Africa, Australia

Viking Mašek, a.s. | Průmyslová 1747 | 258 01 Vlašim | Czech Republic

Phone +420 317 850 500 | **Email** info@masek.cz | **Website** www.masek.cz, www.vikingmasek.cz

North and South America

Viking Masek Global Packaging Technologies, Inc. | 40 Woodland Court | Oostburg, WI 53070 | USA

Phone +1 920 564 5051 | **Email** sales@vikingmasek.com | **Website** www.vikingmasek.com